

Pneumatic Tip Lift



*Unit shown with pneumatic tooth release

Hoist mounted roll handling equipment designed to quickly and safely lift and rotate a roll.

POWER REQUIREMENTS

90 PSI air and 115 volts, 60 Hertz, single phase, 7 1/2amps required on standard units. Unit equipped with 6-conductor coiled SO cable. All air (no electricity) units available upon request.

SPEED

Adjustable with pneumatic muffler on unit.

TIPPING RESTRICTIONS

No limit to cycles per hour.

WEIGHT

200 lbs with 3" standard probe.

CAPACITY

See chart on page 2.

PROBE

All Tip Lifts probes are interchangeable. Probes Feature a patented design that prevents a roll from being release unless the weight of the roll is supported. This prevent unintentionally releasing the roll when the operator is not ready.



Handle Mounted Controls

Handle mounted controls allow the operator to tip the roll, release the roll (if unit has pneumatic tooth release) and control the hoist while keeping hands in a safe location.

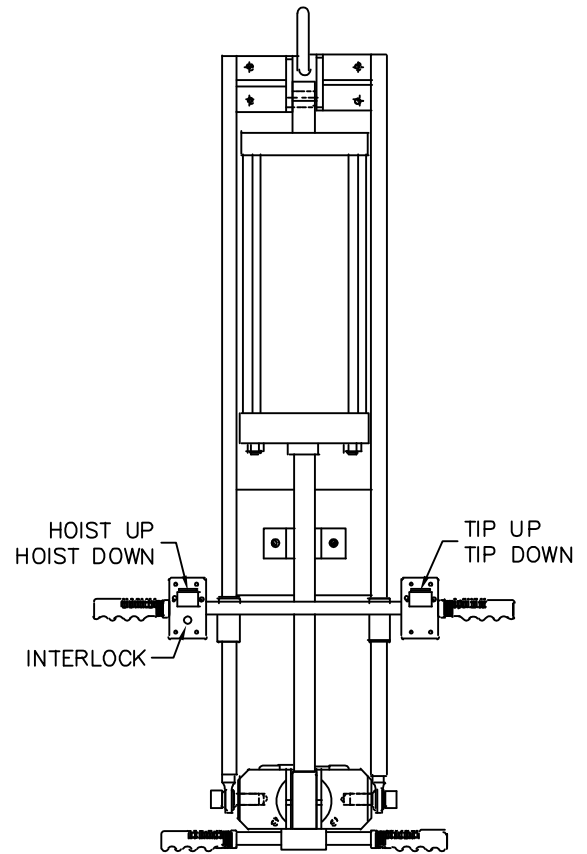
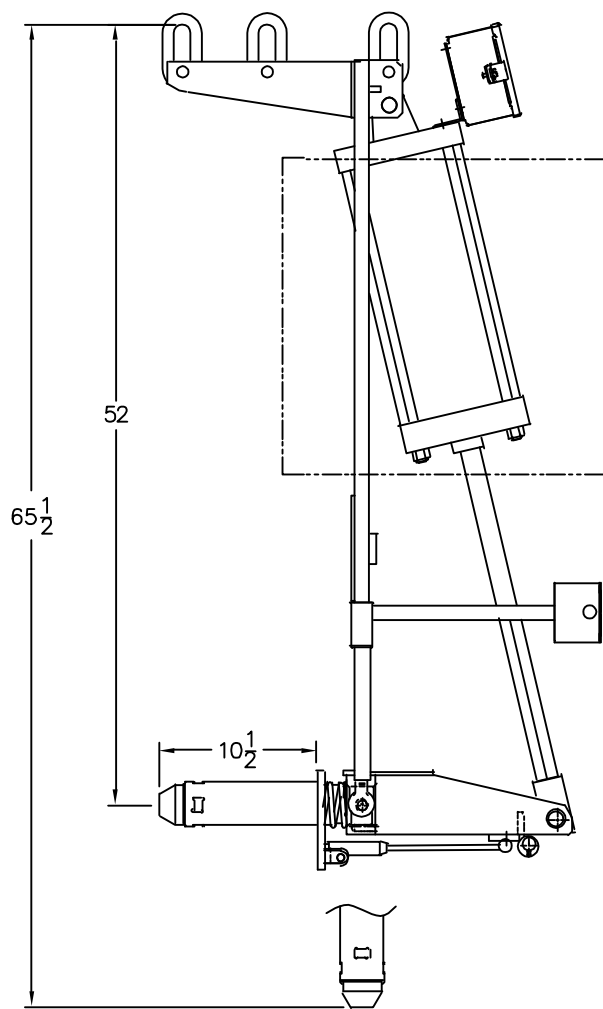

SPECS AND OPTIONS

L3 Pneumatic Tip Lift Capacity							
Roll Face Width	10"	20"	30"	40"	50"	60"	70"
Max Capacity	2000lbs	2000lbs	2000lbs	1650lbs	1350lbs	1150lbs	1000lbs

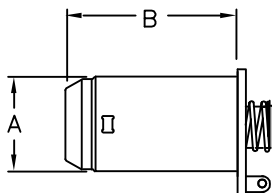

Standard Probe Options		
Type	"A"	"B"
3" Standard	2.875"	10.5"
3" Short	2.875"	6"
6" Standard	5.875"	10.5"
6" Short	5.875"	6"

Custom Probes Available Upon Request.

