



## Hydraulic Cart Attachment

Mobile roll handling cart designed to quickly and safely lift, rotate and maneuver a roll.

### **POWER REQUIREMENTS**

Unit integrated with on board battery. Cart plugs into standard 110V wall outlet to charge.

### **SPEED**

Approximately 10 seconds per tip.

### **TIPPING RESTRICTIONS**

No limit to cycles per hour.

### **WEIGHT**

Attachment weighs 275lbs

### **CAPACITY**

See Chart on page 2.

### **CONTROLS**

Tip up/ Tip down, Mast up/ Mast down, and tooth release controls located near push handles

### **PROBE**

All Tip Lifts probes are interchangeable. Probes Feature a patented design that prevents a roll from being release unless the weight of the roll is supported. This prevent unintentionally releasing the roll when the operator is not ready.



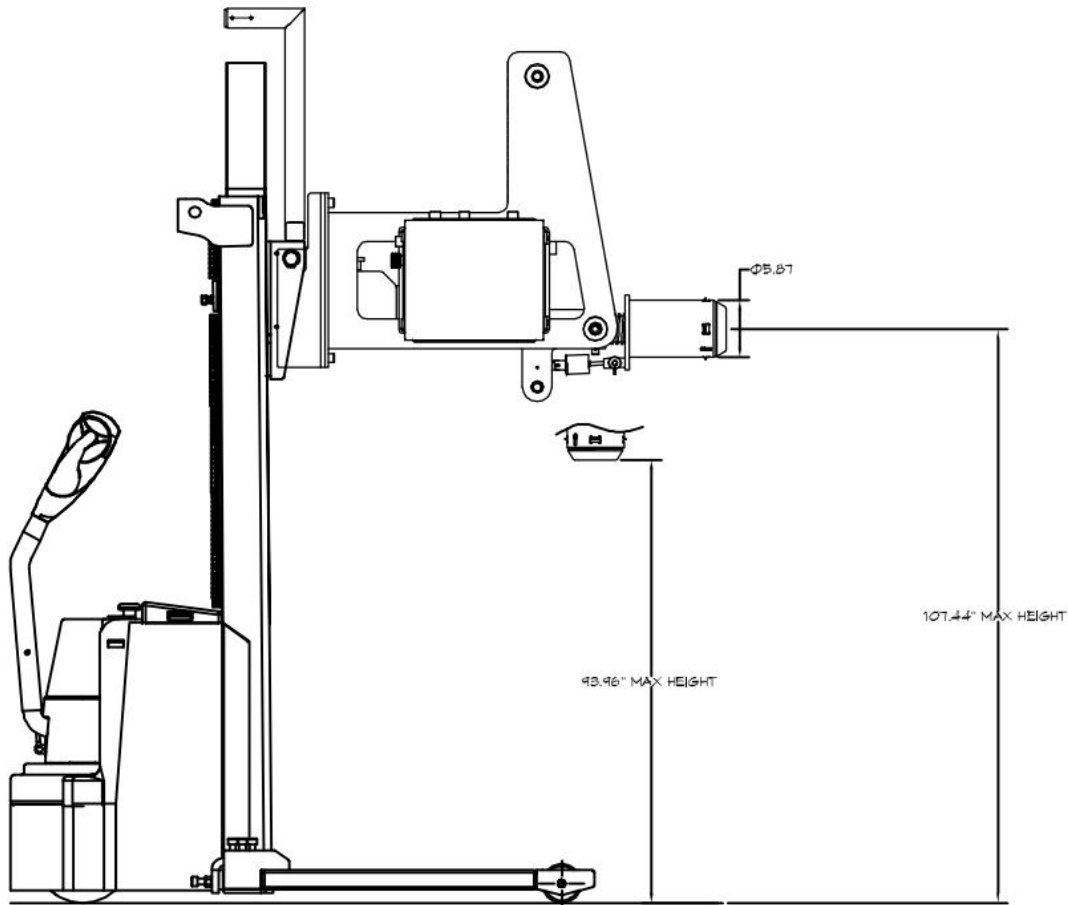

Dimensions show with PPS2200-101

## SPECS AND OPTIONS

Electric Cart Attachment Capacity					
Roll Face Width	10"	20"	30"	40"	50"
Max Capacity	1,570lbs	1,390lbs	1,250lbs	1,135lbs	1,140lbs

\*Capacity varies based on mobile cart capacity.  
Capacity chart based on 3,000lb cart capacity @ 24" LC.

Standard Probe Options		
Type	"A"	"B"
3" Standard	2.875"	10.5"
3" Short	2.875"	6"
6" Standard	5.875"	10.5"
6" Short	5.875"	6"

Custom Probes Available Upon Request.

